

NOTE:-

1. Attempt all questions. There is no negative marking. No additional sheets are provided
2. Answer all the questions of the **same subject at one place**.
3. Students may take around 80 minutes for Mathematics, 50 minutes for Physics and 50 minutes for Chemistry.
4. Use of calculators, slide rule, graph paper and logarithmic, trigonometric and statistical tables is not permitted.

PART-A : MATHEMATICS

Note:- All answers to questions in **Section-A, Section-B** and **Section-C** must be supported by mathematical arguments. In each of these sections order of the questions must be maintained.

SECTION-A

This section has Four Questions. Each question is provided with 4 alternative answers. One or more than one of them are correct answers. Indicate the correct answer by A, B, C, D. (4x3=12 MARKS)

1. The number of solutions of $x + [x] = 2013$, where $[x]$ is greatest integer less than or equal to x , is
A) 2013 B) 0 C) 1 D) not finite
2. If $x \neq -1$, $y \neq -1$ and $x^3 + y^3 + 3xy = 1$ then
A) $x + y = 1$ B) $x + y = -1$ C) $x^2 + y^2 = 1$ D) $(x+y)^2 = 1$
3. A point lying in the plane of a triangle is equidistant from its sides as well as its vertices then the triangle is
A) isosceles but not equilateral B) scalene C) equilateral D) right angled isosceles
4. The complete solution set of $\sqrt{x-2} < 2$ is
A) $(6, \infty)$ B) $(-\infty, 6)$ C) $[2, 6)$ D) $(-\infty, 4)$

SECTION-B

This section has Four Questions. In each question a blank is left. Fill in the blank. (4x3=12 MARKS)

5. The smallest positive integer n such that 2013 is a term in the finite sequence of four numbers $4n, 4n+7, 4n+14, 4n+21$ is _____
6. The radius of the circumscribed circle of an isosceles triangle of unit base is also unity. The diameter parallel to the base of the triangle cuts off a smaller triangle. The exact lengths of the base and legs of the smaller triangle are _____
7. The number of pairs $(f(x), g(y))$ of functions such that $x^2 + xy + y^2 = f(x) + g(y)$ for all $x, y \in \mathbf{R}$ is _____
8. In a parallelogram ABCD if the lengths of two adjacent sides are 2, 6 and the length of the smallest diagonal BD is 6 then $AC^2 =$ _____

SECTION-C

State True or False in each of the following statements. (4x3=12 MARKS)

9. The number of elements in the set $\{x : x(x+8)(x+58) = 2013, x \text{ is an integer}\}$ is 1.
10. The area of the region bounded by $\sqrt{x^2} + \sqrt{y^2} = 1$ is $\frac{1}{2}$ sq. units
11. In a triangle ABC if the internal and external bisectors of angle A meet the circum circle at X and Y then XY is a diameter of the circum circle.
12. If $\frac{x^4 + x^2 + 1}{x^2 + x + 1} = px^2 + qx + r$ then $p + q + r = 1$

SECTION-D

(4x6=24 MARKS)

13. In a triangle ABC, D and E are points on the sides AB and AC such that the line segment DE is parallel to the side BC. F is a point on the line segment AD such that FE is parallel to the line segment DC. If $AF = 4$, $FD = 6$ then find DB.
14. If a, b, c are integers such that $c > 0$. Determine condition(s) on a, b, c to put $a + b\sqrt{c}$ in the form $(\sqrt{p} \pm \sqrt{q})^2$ where p and q are integers.
15. The coordinates of seven vertices of a 7-gon are generated by the following rule:
 $f(x) = (x-7)^2 + 3$ for $x \in \{4, 5, 6, 7, 8, 9, 10\}$. Find the area of the polygon.
16. Find all integers n such that $|2n^3 - 6n^2 + 4n + 3|$ is prime.

PART-B : PHYSICS

(10x6=60 Marks)

17. AB and CD are parallel paths of equal length d . Two persons P and Q start simultaneously from A and C and walk towards B and D with speeds V_1 and V_2 . On reaching the destination they reverse their directions. If V_1 is greater than V_2 where do they cross?

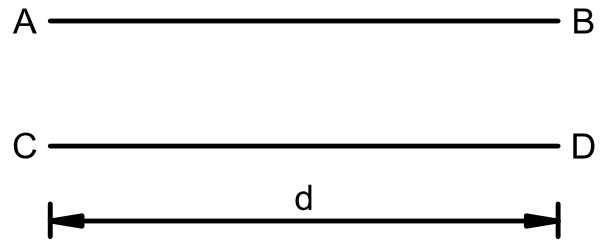

18. A particle starting from rest accelerates uniformly and travels a distance d for some time. It then travels uniformly at the speed acquired after the initial acceleration for an equal time, after which it decelerates and comes to rest. The magnitude of the deceleration is twice the initial acceleration. If total distance travelled is nd , find n .
19. A long straight horizontal wire AB carries some current. A is to the north of B. Magnetic field below the wire is eastward. If the wire is now held vertically with A above B with the current in the wire flowing the same way as earlier, find the direction of the magnetic field to the north of the wire
20. A body of weight W loses $1/3$ of its weight when completely submerged in a liquid A. Find the weight of the body when completely submerged in another liquid B, whose density is half of that of liquid A.
21. Two mirrors AB and CD are placed as shown with their reflecting surfaces towards each other. A ray of light incident on AB at 45° on reflection from AB and CD emerges parallel to the original direction. Through what angle does the ray reflected by CD turn if
- AB is turned in a clock wise sense through a small angle 5° .
 - CD is turned in anticlockwise sense through a small angle 5° .

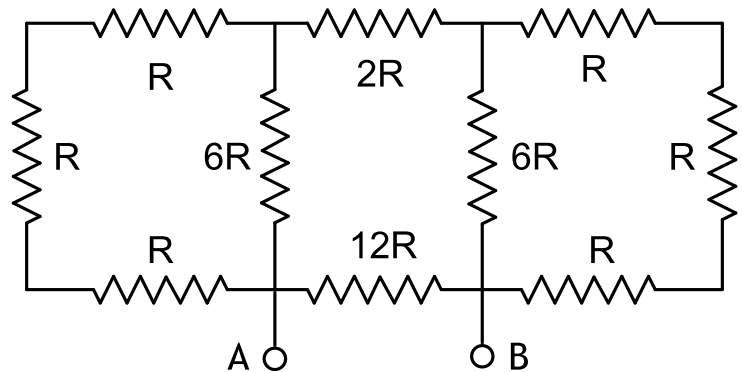
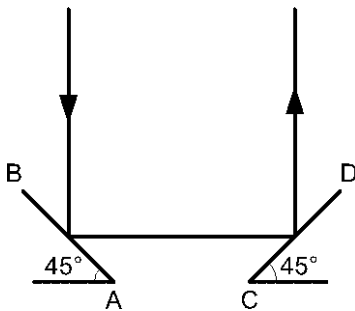

22. Find the equivalent resistance between A and B. Also find the equivalent resistance between A and B if the two resistances of $6R$ are removed.
23. If a nanogram (10^{-9} g) of mass were to be completely converted into electrical energy and used to power a 40 W lamp, find the time for which the lamp can be run. Assume the mass is converted at a uniform rate to produce the power required by the lamp.
24. A proton moving eastward at right angles to a uniform magnetic field experiences a northward force. What is the direction of the force on a beta particle moving southward?
25. Velocity of sound in air at pressure P and temperature T is V . Find the velocity of sound in air if it's
- pressure alone is doubled
 - Temperature alone is doubled
 - pressure and temperature are both doubled
26. What temperature raise does a 500 W heater cause in 2.5 kg of water in 4.2 min? If this water were to be mixed with another liquid of mass 5 kg whose specific heat is half of that of water, what temperature raise would occur in the mixture in 4.2 min? Assume an average loss of 20% of heat to the surroundings.

PART-C : CHEMISTRY

SECTION-A: Each question is provided with 4 alternative answers. One or more than one of them are correct answers. Indicate the correct answer by A, B, C, D. (5x3=15 MARKS)

27. If an element with atomic number 119 is discovered. What is the position of the element in the modern periodic table
A) 2nd vertical column B) 13th vertical column C) 9th vertical column D) 1st vertical column
28. Now a days there is very important world wide discussion about Environmental pollution and global warming, the Global warming is mainly due to
A) UV radiation B) VIS radiation C) IR radiation D) Depletion of ozone layer
29. The molarity of resultant solution when 100 ml of 0.3 M HNO₃ and 200 ml of 0.3 M H₂SO₄ solution mixed together
A) 0.4 M B) 0.2 M C) 0.3 M D) 0.12 M
30. Your science master has purchased a Hydrogen peroxide bottle from a chemical shop. It was labeled as 10 –volume what do you understand by that
A) 10 ml of H₂O₂ on decomposition produce 1 ml of O₂
B) 1 ml of H₂O₂ on decomposition produce 1 ml of O₂
C) 1 ml of H₂O₂ on decomposition produce 10 ml of O₂
D) The entire bottle carry only 10ml of H₂O₂
31. Which of the following is correct for white phosphorous (P₄) molecule
A) The total number of σ bonds in P₄ molecule is six
B) The total number of lone pairs in P₄ molecule is four
C) The bond angle in P₄ molecule is 60° D) In P₄ molecule each p-atom link to four σ bonds

SECTION-B: In each question a blank is left. Fill in the blank. (5x3=15 MARKS)

32. Among Ti⁺², Co⁺³, Mn⁺³, Ni⁺² the number ions with two unpaired electrons _____
33. A radio active cobalt used for cancer chemotherapy having half life 3 hrs. it was sent to a hospital which is received after 12 hrs. At the time of receiving it was left only 3gms. What was the initial amount _____.
34. CO₂ gas at -78°C gets solidified, known as dry ice. The type of bonds present between CO₂ molecules in dry ice _____
35. For a reaction the equilibrium constant is 1, rate constant for the forward reaction is 100, then find the rate constant for the backward reaction _____
36. When Mercury comes in contact with ozone it loses its meniscus sticks to the walls of the container, known as tailing of mercury. This due to formation of a mercury compound _____.

SECTION-C: Name the compound. (5x3=15 MARKS)

37. Sodium chloride on reaction with K₂Cr₂O₇ of in presence of conc.H₂SO₄ in a dry test tube liberates a red fumes. Name of the red fumes.
38. Magnesium on reaction with atmospheric nitrogen forms nitride. This on Hydrolysis in produces gas.
39. Name of the carbon compound formed when Mg₂C₃ is hydrolysed.
40. Name the Nitrogen compound produced by the decomposition of NH₄NO₃.
41. Chemical name of Tear gas.

SECTION-D (5x3=15 MARKS)

42. For a reaction 2SO₂ + O₂ \longrightarrow 2SO₃. The rate of consumption of SO₂ is 4 x 10⁻² moles/lit/sec. What is the rate of consumption of O₂ is
43. The periodic table consists of 18 groups. An isotope of copper, on bombardment with protons, undergoes a nuclear reaction yielding element X as shown below. To which group, element X belongs in the periodic table?

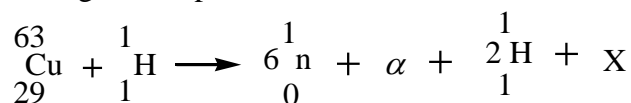

44. Substance A is a gas of vapour density 8.5. On oxidation with pt –catalyst at high temperature it gave a colour less gas B. Which rapidly turned brown in air forming gas C. What are A,B and C.

Give balanced Equations for Q.No. 45–46

45. Cold and dilute NaOH on reaction with Cl₂ produce two compound A and B along with water. In which Cl oxidation number in A is -1 and B is +1.
46. On heating orange solid (P) giving Cr₂O₃ a colourless gas (Q) and water. (Q is most abundant gas in atmosphere).